

APPROVED BY
Director of PARMA Ltd

_____ D.V. Sulimov

____ / ____ 2020

Official Seal

APPROVED by
Deputy Director
FGUP VNIIMS
for Production
Metrology

_____ N.V. Ivannikova

____ / ____ 2020

Official Seal

State system for ensuring the uniformity of measurements

Digital Fault Recorders
«PARMA RP4.11»

METHODS OF VERIFICATION

RA1.004.011MV
with Amendment No. 1

2020

TABLE OF CONTENTS

1	Regulatory references	4
2	Verification operation	4
3	Verification instruments.....	5
4	Conditions for verification	5
5	Safety Requirements	6
6	Preparation for verification	6
7	Verification methods.....	8
7.1	External inspection.....	8
7.2	Trials	8
7.3	Determining (control) metrological characteristics	13
8	PROCESSING THE MEASUREMENT RESULTS.....	20
9	DOCUMENTING THE VERIFICATION RESULTS.....	20

These verification methods apply to the «PARMA RP4.11» Digital Fault Recorders (the "recorder").

The «PARMA RP4.11» Digital Fault Recorder has two versions that differ in the Recorder components overall and connecting dimensions (recording unit, PU16/32M4 units and BPD-128M4 units) and metrological characteristics.

Version 1 is designed for mounting on a panel or wall, and Version 2 is manufactured in a 19" Euromechanics metal enclosure (3U-high recording unit, 2U-high PU16/32M4 and BPD-128M4 units, respectively) for mounting in racks and cabinets.

The PU16/32M4, BPD-128M4 units, which are the components of the recorder Version 2, can be used in the recorder Version 1 and vice versa.

The Recorder consists of a recording unit, an antenna, between one and eleven pieces of PU16/32M4 analog and discrete signal converter units (hereinafter referred to as the PU16/32M4 unit), and/or BPD-128M4 discrete signal converter units (hereinafter referred to as the BPD-128M4 unit) and/or BS-4 output discrete signal units, where one BS-4 unit is always obligatory.

To describe the same functional, technical, and software capabilities of the recorder Version 1 and the recorder Version 2, the verification method uses the following terms:

- recorder (recording unit, PU16/32M4 units, BPD-128M4 and BS-4 units);
- PU16/32M4 unit;
- BPD-128M4 unit.

To describe the differences between the recorder versions, the following terms are used:

- the recorder Version 1 and the recorder Version 2;
- PU16/32M4 unit Version 1 and PU16/32M4 unit Version 2;
- BPD-128M4 unit Version 1 and BPD-128M4 unit Version 2, as well as decimal

numbers of design documentation

The recorder supplied to the Customer may differ in the number of analog and discrete channels, as well as in the composition and measurement ranges of voltage and current. The choice of measurement ranges is carried out by the Customer when submitting the technical assignment, and the initial verification of the recorder is performed only for the established measurement ranges.

The verification method specifies the requirements for the recorder initial and periodic verification.

The recorder verification is carried out by accredited metrological services of state bodies, legal entities, or individual entrepreneurs.

It is permissible to carry out periodic verification for a smaller number of values or for a smaller number of measurement subranges on the basis of a written application from the owner of the measuring device, which can be drawn up in any form.

The recorder's measuring ranges are indicated in its log-book. The recorder must be supplied complete with a log-book for periodic verification.

Recorders that have not passed verification may not be released into circulation and used

Verification interval:

- 4 years for recorder Version 1;
- 8 years for recorder Version 2;

(Revised edition, Amendment No. 1)

1 REGULATORY REFERENCES

Standardization recommendations RMG 51-2002 'State system for ensuring the uniformity of measurements. Documents for the verification methods of measuring instruments. Main principles';

The procedure for verifying measuring instruments, the requirements for the verification mark and the contents of the verification certificate, as approved by Order of the Ministry of Industry and Trade of the Russian Federation No. 1815 dated July 2, 2015;

GOST 32144-2013 'Electric energy. Electromagnetic compatibility of technical equipment. Power quality limits in the public power supply systems';

GOST R 8.736-2011 'State system for ensuring the uniformity of measurements. Multiple direct measurements. Methods of measurement results processing. Main principles';

GOST 12.3.019-80 'Occupational safety standards system. Electrical tests and measurements. General safety requirements';

GOST 12.2.007.0-75 'Occupation safety standards system. Electrical equipment. General safety requirements';

Rules for Technical Operation of Consumers' Electrical Installations approved by the Ministry of Energy of the Russian Federation.

Section 1 (Revised edition, Amendment No. 1)

2 VERIFICATION OPERATION

2.1 During verification, the operations given in Table 1 shall be performed.

Table 1

Verification operation	Number of the paragraph in the Methods of Verification	Operations performed during	
		primary verification	periodic verification
External inspection	7.1	Yes	Yes
Trials	7.2	Yes	Yes
Verification of electrical insulation resistance	7.2.1	Yes	No
Checking insulation dielectric strength	7.2.2	Yes	No
Checking the electrical resistance of analog channels' input circuits	7.2.3	Yes	No
Trials	7.2.4	Yes	Yes
Checking compliance of the software version	7.2.5	Yes	Yes
Determining (control) of metrological characteristics	7.3	Yes	Yes
Determining (controlling) the metrological characteristics of the Recorder function when measuring DC/AC voltage (current)	7.3.1	Yes	Yes
Determining absolute errors of the recorder when measuring AC frequency	7.3.2	Yes	Yes
Determining absolute errors of the recorder when measuring the phase displacement angle between voltage and current	7.3.3	Yes	Yes
Determining the metrological characteristics of the recorder in the PMU function	7.3.4	Yes	Yes
Documenting the verification results	9		

Section 2 (Revised edition, Amendment No. 1)

3 VERIFICATION INSTRUMENTS

3.1 The list of measuring instruments used for verification is provided in Table 2

Table 2

Description	Required specifications		Recommended type	Number of the paragraph in the Methods of Verification
	Measurement range	Error or accuracy class		
Instrument for checking electrical safety parameters	U=0.1...5.0 kV R=1...9999 MΩ	ERR U=±(0.01*Uind.+5 LSD); ERR R±5 % at (R = 1 to 500 Ω ERR=±10 % at R = 500 to 9999 MΩ	GPI – 735A State Register Entry No. 46633-11	7.2.1, 7.2.2
Universal digital voltmeter	10 MΩ 750 V	ERR ±(0.003*X+5k)% ERR ±(0.00012*X+2k)%	GDM-78251A State Register Entry No. 38428-08	7.2.3
Multifunction reference voltage and current calibrator	U = 0...308 V, I = 0...7 A F= 45...55 Hz φ=0...360°	ERR ± 0,02+ 0,0015x x(Uf/Um-1)% ERR ± 0,1 + 0.005(I _f /I _m -1)% ERR±0.001 Hz ERR±0.02°	«PARMA GS8.03» 3.2.GKK.0002. 2015	7.3.1
Power Sentinel multifunction reference meter	U = 0...600 V, I = 0...20 A F=45...55 Hz φ=0...360°	ERR ± 0.002/0.02%; ERR ± 0.003/0.03% ERR±0.001 Hz ERR±0.02°	1133 A 3.2.GKK.0003. 2015	7.3.4
Multifunction calibrator	U 1000 V, I 30 A f 20 MHz φ 360°	ERR ± (0.005U _X + 0.03U _K) ERR ± (0.10 I _X +0.03 I _K) ERR f= ± 0.005 % ERR φ = ± 0.15°	«CALIBRO 142» State Register Entry No. 39949-15	7.3.1- 7.7.2
Humidity and temperature meter	10...98 % 0...50 °C	ERR ±5 % ERR ±0.5 °C	TKA-PKM	4.1
Special aneroid-barometer	80...106 kPa	ERR ±0.2 kPa	BAMM-1	4.1

3.2 Other instruments may be used to ensure measurement of the relevant parameters with the required accuracy.

Section 3 (Revised edition, Amendment No. 1)

4 CONDITIONS FOR VERIFICATION

4.1.1 Verification is performed under standard application conditions

4.1.2 Standard conditions for using the recorder in accordance with GOST 22261:

4.1.3 Nominal ambient air temperature 20°C. Permissible deviation of ambient air temperature ±5 °C.

4.2 Voltage of the power supply network of the recorder, depending on the Version:

– from AC mains, 50 Hz, 230 V of the RMS value of voltage. Allowable deviation of the normal value during verification is ± 10 V. The distortion factor of the voltage curve

sinusoidality is not more than 5 %. Remaining characteristics of the AC network must comply with GOST 32144-2013;

- from a direct current source with a rated voltage of 110 V.

Section 4 (Revised edition, Amendment No. 1)

5 SAFETY REQUIREMENTS

5.1 Before performing a verification, the following preparatory work must be completed:

- technical and organizational measures to ensure work is carried out safely and in accordance with the applicable provisions of GOST 12.2.007.0-75 and GOST 12.2.007.3-75;
- preparing verification measuring instruments in accordance with their operating manuals (all measuring instruments must be in good working order and have confirmation of their suitability for use).

5.2 General safety requirements for verification are in accordance with GOST 12.3.019-80.

ATTENTION! Do not switch on the recorder with unconnected optical cables or optical transmitters missing protective caps.

6 PREPARATION FOR VERIFICATION

6.1 Verification instruments must be prepared in accordance with the guidelines given in the relevant operational documents.

6.2 Prior to verification, the verification specialist must carefully read the relevant operational documentation for the device and its components.

6.3 Since the recorder is a multifunctional measuring device, and the name and measurement ranges are determined by the Customer when submitting the technical assignment (order blank) for manufacturing of the recorder, the measurement ranges of voltage and DC/AC current may be missing. The distribution of measured values of each recorder is given in its log-book and on the USB flash drive. It is obligatory to submit the log-book of the PU16/32M4 units and the file with the '.ini' extension for periodic verification.

6.4 Record the values for the recorders in the file with the '.ini' extension to verify the AC frequency and phase displacement angles. For example: numbers of channels for measuring current and voltage (Channel01:Ia, Channel13:Ua, etc.).

[Self-recording device]

Time = 1.0

Record discrete = 0

Storage period = 8,

1 = EffectiveValue(Channel01:Ia)

2 = Frequency (Channel01:Ia)

3 = 1 = EffectiveValue(Channel13:Ua)

4 = Frequency (Channel13:Ua)

5 = PhaseDisplacementAngle(Channel13:Ua,Channel01:Ia)

6 = PhaseDisplacementAngle(Channel13:Ua, Channel13:Ub)

6.5 Recorder verification is carried out within the ranges and scope of items of this verification method by the measured values specified in the log-book of each PU16/32M4 unit of the recorder.

6.6 If the recorder (PU16/32M4 units) does not contain channels for measuring voltage or DC/AC current, the determination of measurement errors is not carried out.

6.7 When recording positive results of the verification, it is required to specify the measurement ranges, according to which the verification of a particular recorder was carried out.

6.8 Assemble the circuit as shown in Figure 1 to determine the errors for measuring DC/AC voltage (current) channels, AC frequency and phase displacement angles between voltage and current.

6.9 Join the inputs of the channels for measuring voltage and the recorder's AC current to the terminals of the «PARMA GS8.03» calibrator (as shown in Figure 2) to determine the errors for measuring phase displacement angles between voltages and between voltage and current.

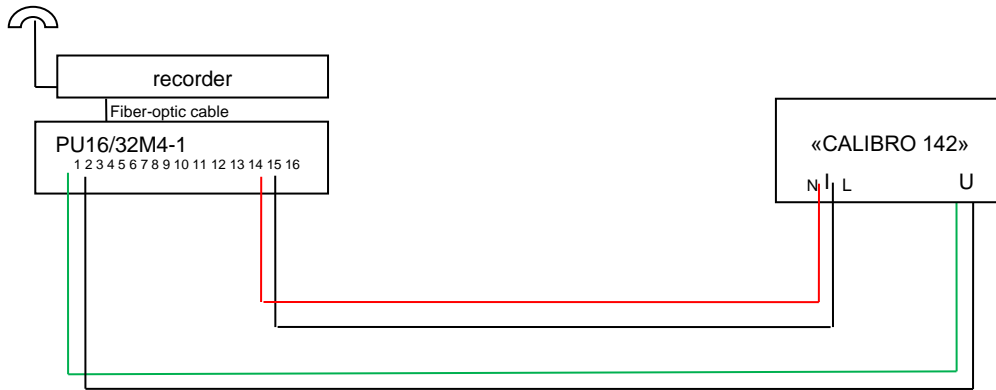

Figure 1a - Connection diagram for the PU16/32M4 unit Version 1

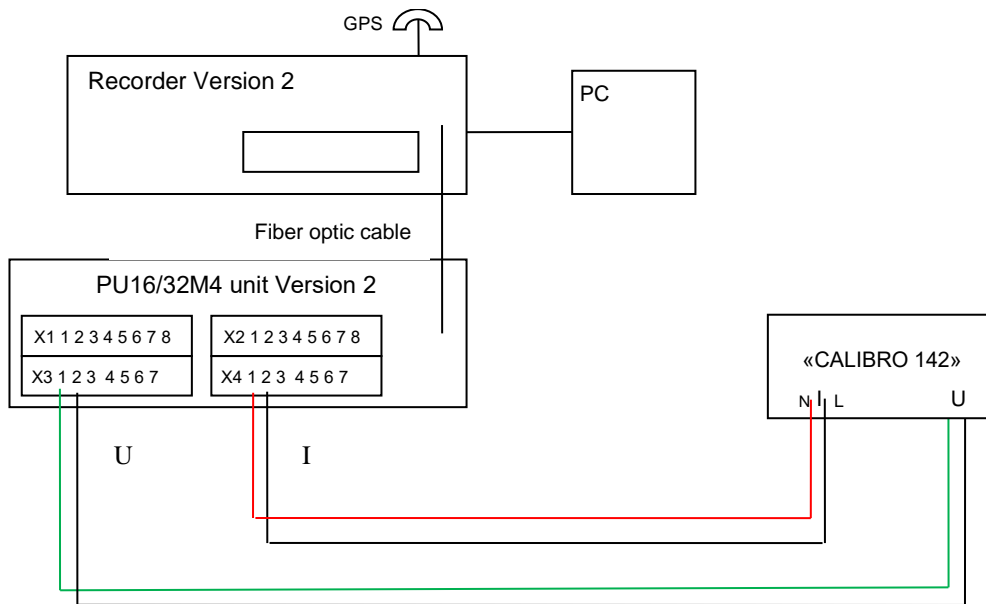

Figure 1b - Connection diagram for the PU16/32M4 unit Version 2

Figure 1

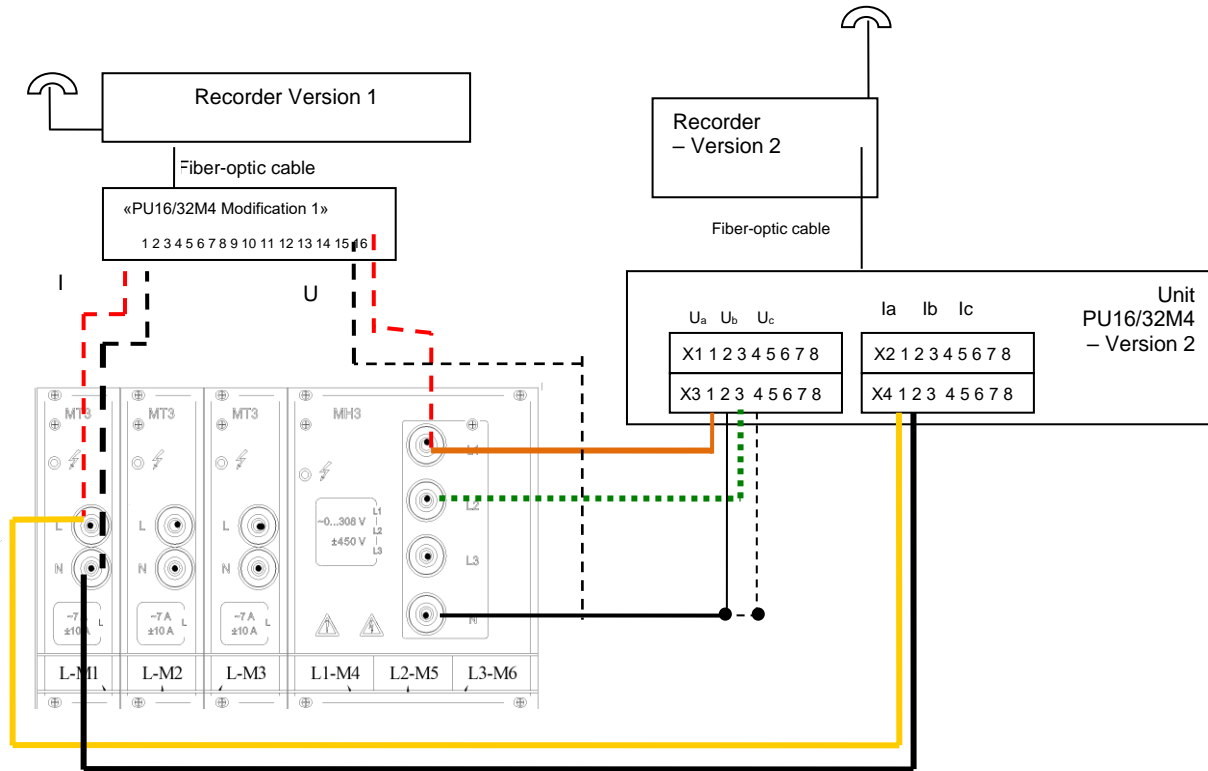

Figure 2

ATTENTION! Do not switch on the recorder with unconnected optical cables or optical transmitters missing protective caps.

Section 6 (Revised edition, Amendment No. 1)

7 VERIFICATION METHODS

7.1 External inspection

7.1.1 The appearance check is carried out by inspection. The recorder (recording unit, PU16 / 32M4, BS-4 and BPD - 128M4 units) and components shall have no visible external damage to its body, nor dents, breaks, or skewed elements.

7.1.2 The marking of the hardware, component parts, and cables must be legible and show no signs of damage.

7.1.3 If any damaged parts are discovered, the recorder is rendered defective and the verification process is terminated.

7.2 Trials

7.2.1 Verification of electrical insulation resistance

7.2.1.1 Compliance with the requirements is checked using the GPI-735A electrical safety device (the "GPI-735A device").

7.2.1.2 Recording unit.

Version 1

Join the "live" and "neutral" contacts of the power plug of the recording unit to form C0 contact. Combine the power plug's grounding contact with the recording unit encasement.

Set the voltage to 1000 V on the GPI-735A unit and measure the insulation resistance between the C0 contact and the joined together ground contact of the power plug and the unit's encasement.

Version 2

Join the contacts of the recorder as follows:

- the "live" and "neutral" contacts of the power supply terminal block of the recorder to form a contact – C0;

Set the voltage to 1000 V on the GPI-735A device and measure the insulation resistance between the contacts:

- join the "ground" contact and the C0 contacts together;

Remove the voltage. Record the test results in the test report.

Using a V7-40 voltmeter, measure the resistance value between the grounding bolt and the recorder encasement.

7.2.1.3 PU16/32M4 unit.

Version 1

Join the "N" and "L" contacts of the power supply circuit to form a C0 contact.

Join the input contacts of analog channels (contacts 1 and 2, 3 and 4, 5 and 6, etc.) to form contacts C1, C2, C3, ..., C16.

Join all the contacts of the inputs of discrete signals (contacts 33, 34 and 39 to 70) to form contact C17.

Wrap the unit encasement with copper or aluminum foil and connect it to the protective ground contact of the power terminal to form a ground contact.

Set the voltage to 1000 V on the GPI - 735A device and measure the insulation resistance in sequence between the following:

- between the ground contact and contacts C0, C1, C2, ..., C16, C17 joined together;
- between the contacts C0 and C17;
- between contact C1 and contacts C0, C2, ..., C17 joined together;
- between contact C2 and contacts C0, C1, C3 ..., C17 joined together;
- between contact C2 and contacts C0, C1, C2, C4..., C17 joined together;
- etc.
- between contact C16 and contacts C0, C1, C3 ..., C17 joined together;

Version 2

Join the contacts of the PU16/32M4 unit as follows:

- the "live" and "neutral" contacts of the power supply terminal block to form the C0 contact;
- join all analog inputs to form the C1 contact;
- join all discrete inputs and outputs to form the C2 contact.

Set the voltage to 1000 V on the GPI-735A device and measure the insulation resistance between the contacts:

- C0 and C1 contacts;
- between C0 and C2 contacts;
- between the ground contact and C1, C2 contacts joined together.

Remove the voltage. Record the test results in the test report.

Using a V7-40 voltmeter, measure the resistance value between the grounding bolt and the recorder encasement.

7.2.1.4 BPD-128M4 unit.

Version 1

Join the 129 and 130 ("N" and "L") contacts of the power supply circuit to form a C0 contact.

Join all contacts of inputs of discrete signals (contacts from 1 to 128, including contact 131 ("-D")) to form a C1 contact.

Wrap the unit encasement with copper or aluminum foil to form a ground contact.

Set the voltage to 1000 V on the GPI-735A device and measure the insulation resistance in sequence:

- between the C0 and ground contacts, combine with the C1 contact;
- between the C0 and ground contacts, combine with the C1 contact;

Version 2

Join the contacts of the BPD-128M4 unit as follows:

- the "live" and "neutral" contacts of the power supply terminal block to form the C0 contact;

- join all discrete inputs and outputs to form the C1 contact.

Set the voltage to 1000 V on the GPI-735A device and measure the insulation resistance between the contacts:

- C0 and C1 contacts;
- the "ground", C0, and C1 contacts joined together;

Remove the voltage. Record the test results in the test report.

Using a V7-40 voltmeter, measure the resistance value between the grounding bolt and the recorder encasement.

7.2.1.5 BS-4 unit

Join contacts 1 and 2 of the BS-4 unit power circuits to form a C1 contact

Join all contacts of inputs of discrete output signals (contacts from 3 to 10) to form a C2 contact.

Wrap the unit encasement with copper or aluminum foil in accordance with GOST 12.2.091 to form a ground contact.

Set the voltage to 1000 V on the GPI - 735A device and measure the insulation resistance in sequence:

- between the "ground", C1, and C2 contacts joined together.
- between contact C1 and contacts C2,

7.2.1.6 The recorder is considered to have passed the test if the insulation resistance is at least $2\text{M}\Omega$, and the measured grounding resistance between the grounding bolt and its encasement is no more than $0.1\text{M}\Omega$.

7.2.2 Testing the dielectric strength of insulation of the recorder

7.2.2.1 Compliance with the requirements is checked using the GPI-735A device.

7.2.2.2 Tests of the dielectric strength of the insulation of the recorder are conducted in accordance with the requirements and methods of GOST 12.2.091.

7.2.2.3 Join the contacts of the recording unit Version 1 and the recording unit Version 2 in accordance with 7.2.1.2; the contacts of the PU16/32M4 units Version 1 and PU16/32M4 units Version 2 in accordance with 7.2.1.3; the contacts of the BPD-128M4 unit Version 1 and the BPD-128M4 unit Version 2 in accordance with 7.2.1.4; and the contacts of the BS-4 unit in accordance with 7.2.1.5 of the present Method of Verification.

7.2.2.4 Place the recording unit, PU16/32M4 unit, BPD-128M4 units Version 1 and Version 2 and BS-4 unit successively in a high-voltage blocking chamber.

7.2.2.5 Recording unit.

for the recording unit Version 1

– Apply a test voltage of 1.35 kV, 50 Hz between the shorted circuits of the network and the ground contact;

for the recording unit Version 2

– Apply a test voltage of 3.3 kV, 50 Hz between the shorted circuits of the network ("live" and "neutral" of the power plug joined together) on one side and the grounding bolt on the other side;

For verification of the dielectric strength of the insulation, increase the test voltage to the specified value within 5s, and hold for 3s, electrically isolating the circuit from any external grounding means. Remove the voltage.

7.2.2.6 PU16/32M4 unit.

for the PU16/32M4 units Version 1

Apply a test AC voltage of 3.7 kV, with frequency of 50 Hz, between the ground contact on one side and C0 - C17 contacts joined together on the other side.

Apply a test voltage of 1.35 kV, 50 Hz between the following contacts:

- between C0 and C17 contacts;
- between contact C1 and contacts C0, C2, ..., C17 joined together;
- between contact C2 and contacts C0, C1, C3 ..., C17 joined together;
- between contact C2 and contacts C0, C1, C2, C4..., C17 joined together;

- etc.
- between contact C16 and contacts C0, C1, C3 ..., C17 joined together;

For the PU16/32M4 unit Version 2

Apply a test AC voltage of 3.3 kV, 50 Hz between the following contacts:

- C0 and C1 contacts;
- between C0 and C2 contacts;
- between the ground contact and C1, C2 contacts joined together.

Apply a test voltage of 4.3 kV, 50 Hz between all the joined contacts of the analog inputs (650 and 1000 V) and the ground contact.

For verification of the dielectric strength of the insulation, increase the test voltage to the specified value within 5s, and hold for 3s, electrically isolating the circuit from any external grounding means. Remove the voltage.

7.2.2.7 BPD-128M4 unit

for the BPD-128M4 unit Version 1

Apply a test voltage of 1,35 kV between contacts C0 and C1.

Apply a test voltage of 3,7 kV between the ground contacts and contacts C0 and C1 joined together.

for the BPD-128M4 unit Version 2

Apply a test voltage of 3.3 kV, 50 Hz between the following contacts:

- C0 and C1 contacts;
- the "ground", C0, and C1 contacts joined together;

For verification of the dielectric strength of the insulation, increase the test voltage to the specified value within 5s, and hold for 3s, electrically isolating the circuit from any external grounding means. Remove the voltage

7.2.2.8 BS-4 unit

Apply a test voltage of 1.35 kV between contacts C2 and C1.

Apply a test voltage of 3.7 kV between the ground contacts and contacts C2 and C1 joined together

For verification of the dielectric strength of the insulation, increase the test voltage to the specified value within 5s, and hold for 3s, electrically isolating the circuit from any external grounding means. Remove the voltage

7.2.2.9 The recorder and the recorder in the cabinet are deemed to have passed the tests if no insulation breakdown occurs as a result of the tests.

7.2.3 Checking the electrical resistance of analog channels' input circuits

7.2.3.1 Measure the input resistance of analog channels for measuring the current.

7.2.3.2 Perform measurements using E6-18 / 1 milliohmmer and V7-34A voltmeter.

7.2.3.3 The input resistance of the channels for measuring the current strength must correspond to the values specified in Table 3.

Table 3

For the PU16/32M4 units Version 1					
The limit value of the recorded AC current in the channel, A	0.005	0.02	0.2	0.5	For the rest of the channels
The input resistance value, not exceeding, Ω	50	50	1	0.3	0.025
For the PU16/32M4 unit Version 2					
The limit value of the recorded AC current in the channel, A	0.005	0.02	0.35	For the rest of the channels	
The input resistance value, not exceeding, Ω	10	2	0.3	0.2	

7.2.3.4 The input resistance of electrical circuits for measuring DC voltage must be at least equal to the value given in Table 4.

Table 4

For the PU16/32M4 units Version 1							
The limit value of the recorded DC voltage in the channel, V	20			For the rest of the channels			
The input resistance value, not exceeding, Ω	500			1500			
For the PU16/32M4 unit Version 2							
The limit value of the recorded DC voltage in the channel, V	0.2	1.0	20.0	100.0	200.0	260.0	For the rest of the channels
The input resistance value, not exceeding, Ω	3.0	10	10	250	450	600	1000

7.2.3.5 If the requirements of 7.2.3.3 and 7.2.3.4 are not met, the recorder shall be deemed defective, verification is terminated, and the recorder must be repaired.

7.2.4 Trials

7.2.4.1 If an antenna is used as a synchronization source, it is necessary to install the antenna in advance to provide a stable signal from the satellites and connect it to the corresponding connector on the measuring unit. If an external time server with supporting IRIG-B (TTL/fiber optic) is used as a synchronization source, it is necessary to connect the recorder via fiber optic to the synchronization source.

7.2.4.2 Connect the PU16/32M4, BPD-128M4 and BS-4 units to the recording unit and to the AC network. First, using a circuit breaker, connect PU16/32M4 units, BPD-128M4 and BS-4 units, and then switch on the power supply to the recording unit.

7.2.4.3 After turning on the power, make sure that the POWER LED on the front panel lights up, and the recorder software is loaded on the display of the measuring unit.

7.2.4.4 After the automatic loading of the software, the "OPERATION E:0 S* C:3** 15:26:00***" message should light up on the display of the recording unit.

Note:

- E:0 – errors "0".
- S* – starts – the indication appears only if there are available startup files
- C** – communication with satellites of the GPS / GLONASS system, N – accuracy of synchronization with UTC, N values vary from 3,4,5,6,7,8,9, A, B, C, D, E, F, if there is no F-synchronization, the synchronization accuracy is worse than 1s, if 3 – the synchronization accuracy is 10-7 s –. If N value is 3 or 4, the recorder is operational. If there is no external synchronization, then always F.

– *** – time is shown conventionally.

7.2.4.5 The recorder is in working order and is put into operation.

7.2.4.6 If the status bar on the indicator of the recording unit lights up, enable the recording process (to start the recorder). To do this:

- press Enter and go to the local control menu;
- find 5 SERVICE and press Enter;
- find the START RECORDER command, select YES, and press Enter.

7.2.4.7 There should be an audible message confirming the recorded process (a beep).

7.2.4.8 The verification results are considered favorable if the status bar lights up, communication with satellites is established, the recorder has started up, and there has been an audible confirmation (a beep) of the recorded process.

7.2.4.9 If any error message lights up on the indicator of the recording unit, the recorder is faulty. It must be disconnected from the power supply (all units).

7.2.4.10 If any deviations occur, the verification is terminated, and the recorder is considered defective.

7.2.5 Checking compliance of the software version

7.2.5.1 The embedded software (hereinafter, "software") can be checked, installed, or reinstalled only at the manufacturer with the use of special software and hardware devices; therefore, the embedded software is not checked during verification.

7.2.5.2 To verify the software version of the recorder, you must do the following:

- using the local control keys, enter the recorder menu and find menu 6 – INFORMATION;
- press the Enter (↵) button, then consistently press the button ↓ until menu 6.3;
- see the software version.

7.2.5.3 The software version number must be at least 7.53.0.40

7.2.5.4 The test result is considered positive if the software version is no lower than that specified.

7.3 Determining (control) metrological characteristics

7.3.1 Determining of recorder errors when measuring voltages and currents in the Recorder function

7.3.1.1 Determining errors for measuring DC/AC voltage (current) is carried out by the direct measuring method.

7.3.1.2 The procedure for verifying the ranges and determining the measurement errors of the recorder's DC/AC voltage (current) is automated. During verification the measured values for each channel, which must be applied to the inputs of the corresponding channels, are displayed on the recorder indicator when implementing the CHECK menu item.

7.3.1.3 To activate the CHECK menu item, press Enter on the local control panel, and the recorder will go to the local control menu.

7.3.1.4 In the local control menu find menu 5 SERVICE and press Enter.

7.3.1.5 Using the navigation arrows in menu 5 SERVICE, find menu item 5.4 PERIODIC VERIFICATION and press Enter.

7.3.1.6 The first item in the menu is the selection of the PU converter unit (of PU16/32M4 unit).

VERIFICATION OF PU N
[START] SKIP

Where N is the PU index.

7.3.1.7 If the SKIP item is selected, the next PU will be offered.

7.3.1.8 After selecting the PU converter, the screen for selecting the **measured value** (channel) will appear on the display:

VERIFICATION Measured value
[START] SKIP

7.3.1.9 If the SKIP item is selected, the next measured value will be offered.

7.3.1.10 After selecting the measured value, the following screen will appear

N. Measured value
APPLY U value (coefficient)

Where:

N is the channels' serial number on the PU16/32M4 unit, connected at a given time.

Measured value is the indication of the measured value by the current channel.

value is the value of the measured value, which must be supplied to channel input.

U – units of measure of the supplied value: V – volts, A – amperes. For DC values, a + sign is explicitly indicated in front of the measured value. For AC values, a ~ (tilde) sign is explicitly indicated in front of the measured value.

coefficient is – the factor determining the meaning of the measured value depending on the measurement limit of the current channel (0.1; 0.3; 0.5; 0.75; 1.0).

The channels of the PU16/32M4 unit Version 1, with the set limits of 40, 60, 80, 100, 150, and 200 A of the AC Current's RMS value, and the channels of the PU16/32M4 unit Version 2, with the set limits of 36, 60, 120, and 200 A are standardized and tested up to 30 A.

7.3.1.11 The DC/AC voltage channel with a measuring range of 0.14/0.2 V - HV-0.14/0.2 module, used only for measuring the excitation current – connect to the calibrator («CALIBRO 142» / «PARMA GS8.03») through resistance coil P321, nominal 0.1 MΩ.

Connect an appropriate verification tool to the PU16/32M4 unit's channel N input and set it to the range of the channel's measured value.

On the calibrator, form and apply the measured value to the channel input, as indicated on the recorder indicator (value). When the signal (the measured value) is formed and applied to the inputs of the PU16/32M4 unit, press the Enter key on the front panel of the recording unit. The indicator will show the current value of the measured value. After the current value appears, press the + button to write the result to the verification report and to go to the next measured value.

The measurement result will be recorded, and the indicator will offer to supply the value of the measured value of the next verified point.

The values of the relative error in the measurement of voltages and currents are determined by formula (1), and those of the reduced errors by formula (2)

$$\delta A = 100 \cdot \frac{A_R - A_k}{A_k}, \% \quad (1)$$

where A_k is set value of the parameter

A_R is value of the parameter measured by the recorder

$$\gamma A = 100 \cdot \frac{A_R - A_P}{A_D}, \% \quad (2)$$

where A_P is set value of the parameter

A_R is value of the parameter measured by the recorder

A_D is measuring range, for example for voltage channels: 140, 460 V, etc., in accordance with Table 1 and 2, and for current channels 4, 6.5, 30 A, etc., in accordance with Table 1 and 2, respectively

After verifying all points in the range, the next channel will be offered.

7.3.1.12 Remove the test signal on the calibrator, disconnect the channel that has passed the verification, and connect the next one.

7.3.1.13 In the same way, control the metrological characteristics and determine the measurement errors for all channels of the recorder. To ensure a higher reliability of verification results during initial verification, the permissible errors in the verified points at these limits are set with a production margin (0.8 of the normally permissible error value).

7.3.1.14 After verification is complete, the screen for recording the results of the Flash drive will appear.

7.3.1.15 Connect the Flash drive to the USB connector located on the front panel of the measuring unit and press Enter to record the verification report. When selecting the Cancel item, the verification results will be saved on the recorder's hard disk drive until the next verification or until the hard disk drive is formatted.

7.3.1.16 Insert a USB flash drive into the computer's USB connector and open a text file (with the .txt extension). This file will contain a table of measurement results with the calculated error values for all the verified points at each range. The points of the ranges of the measured quantities, the error values are outside the permissible limits, will be marked with an "*" (asterisk).

7.3.1.17 The results of the verification are deemed favorable if the recorder's measurement range and errors when measuring the DC/AC voltage (current) comply to the description type; if this requirement is not met, the recorder is deemed faulty and must be repaired.

7.3.2 Determining the recorder's permissible error when measuring the AC frequency in the Recorder function mode

7.3.2.1 Determining the absolute errors of the recorder when measuring the AC frequency is carried out using direct measuring method with the «CALIBRO 142» calibrator.

7.3.2.2 Depending on the measured values of voltage and/or AC current set in the recorder, connect the input of any channel to measure AC voltage or AC current to the «CALIBRO 142» calibrator.

7.3.2.3 Using the local control keys, enter the recorder menu, find menu 3 CURRENT MEASUREMENTS, press Enter (↵), then press the key ↓ until you see menu 3.2 SELF-RECORDERS and press Enter(↵).

7.3.2.4 On the calibrator, depending on the measured values, form a voltage or AC signal of 0.5 of the measurement range with a frequency of 40 Hz and apply it.

7.3.2.5 The recorder display will show the following:

- the top line displays the number and designation of the channel on which the AC frequency is verified,
- the second line displays the value of the AC frequency measured by the recorder.

7.3.2.6 Read the value of the AC frequency of 40 Hz measured by the recorder and record the result in the verification report.

7.3.2.7 Determine the recorder's absolute errors when measuring the frequency of the alternating current according to formula (3).

$$\Delta f = f - f_0 \quad (3)$$

where F is the parameter value measured by the recorder

f_0 is set value of the parameter

7.3.2.8 In the same way, form, apply and measure the frequency of voltage and AC current for values of 45, 50, 55, 60, and 65 Hz. Record the result in the verification report. Calculate the measurement errors according to the formula (3) and record the results in the verification report.

7.3.2.9 The verification results shall be considered favorable if, when measuring the voltage frequency and AC, the recorder's measurement range and absolute errors do not exceed the values of the limits of the permissible absolute measurement error ± 0.05 Hz; if this requirement is not met, the recorder is deemed faulty and must be repaired.

7.3.3 Determining recorder errors when measuring the phase displacement angles between voltage and current

7.3.3.1 Determining recorder errors when measuring phase displacement angles is carried out using the direct measuring method with the «PARMA GS8.03» calibrator.

7.3.3.2 Connect the inputs of any voltage measurement channels to the «PARMA GS8.03» calibrator, as shown in Figure 2. On the calibrator, set the AC voltage to 0.5 of the measurement ranges, for example: for the AC voltage measurement range (0.07-140) V, 0.5 equals 70 V, for AC current (0.001 - 2.000) A 0.5 equals 1.0 A.

7.3.3.3 On the calibrator, form a test signal of 70 V AC voltage, 1.0 AC, set the frequency to 50 Hz, and the phase angle between the voltage channels to 0° and apply it.

7.3.3.4 Using the local control keys, enter the recorder menu, find menu 3 CURRENT MEASUREMENTS, press Enter (↵), then press the key ↓ until you see menu 3.2 SELF-RECORDERS and press Enter(↵).

7.3.3.5 The recorder display will show the following:

- the top line shows the number and designation of the channels between which the phase displacement angle is verified;
- the second line displays the value of the phase displacement angle between them as measured by the recorder.

7.3.3.6 Read the value of the phase displacement angle measured by the recorder and record the result in the verification report. For values close to zero, the recorder display will show a value, for example "-10 m°". In other words, the phase displacement angle between the voltages measured by the recorder is displayed with a scaling factor equal to "minus 10 miles degrees", which corresponds to 0.01°.

7.3.3.7 Determine the recorder's absolute error when measuring the phase displacement angle using a formula similar to the formula (3).

7.3.3.8 In the same way, form, apply, and measure the phase displacement angles for values of minus 30, 30, 60, 90, 180, and 270°. Record the measurement result in the verification report, calculate the measurement errors according to the formula (3), and record the results in the verification report.

7.3.3.9 The verification results shall be deemed favorable if, when measuring the phase displacement angle, the recorder's measurement range and errors do not exceed the values of the permissible absolute error $\pm 0.5^\circ$; if this requirement is not met, the recorder is deemed faulty and must be repaired.

7.3.4 Determining the recorder's error when measuring parameters in the PMU function

7.3.4.1 Verification is carried out by direct measuring method using the «CALIBRO 142» / «PARMA GS8.03» calibrators, the 1133A meter, and the UVItest software.

7.3.4.2 The recorder may be missing the PMU mode; if so, do not perform verification of this parameter.

7.3.4.3 The availability of the recorder's PMU mode and the distribution of measured values by channel and designation are indicated in each recorder's log-book.

7.3.4.4 The DC/AC voltage channel with a measuring range of 0.1/0.2 V - HV-0.1/0.2 module is used only for measuring the excitation current – connect to the calibrator («CALIBRO 142» / «PARMA GS8.03») through resistance coil P321, nominal 0.1 MΩ.

7.3.4.5 Install the antenna of the 1133A meter and the recorder to ensure a stable signal from the GPS/GLONASS, and connect the antenna to the respective inputs of the 1133A meter and recorder. If another resource is used to synchronize the recorder, connect it to the corresponding connector on the recorder.

7.3.4.6 Install the UVItest and PSCSV™ software onto your PC.

7.3.4.7 Launch the PSCSV™ software and establish a physical connection with the 1133A meter via the Ethernet TCP switching port. After establishing connection, register (specify the password and login, the default password is admin login 801n60) to access the settings and obtain information in the PSCSV™ software.

7.3.4.8 In the PSCSV™ software, select Connection menu> Configure> Communication Ports> C37.118 PMU1, (Figure 3a)) set up for the 1133A meter:

- Input – for transmission of parameters via the C37.118 protocol PMU-1 – all On;
- Window Length - 8;
- Estimated Rate, Hz - the number of signals sampled in s - 50 HZ
- Nominal Freq – 50 Hz

7.3.4.9 Set the configuration parameters of the Ethernet port, Figure 3b). From the drop-down list for PMU-1 C37.118, select the TCP protocol and write down the TCP port number (4716, Figure 3b)) as defined by the PSCSV™ software (the TCP port number is required to communicate with the 1133 A meter in the UVITest software), and press the OK button to write parameters into the memory of the 1133A meter.

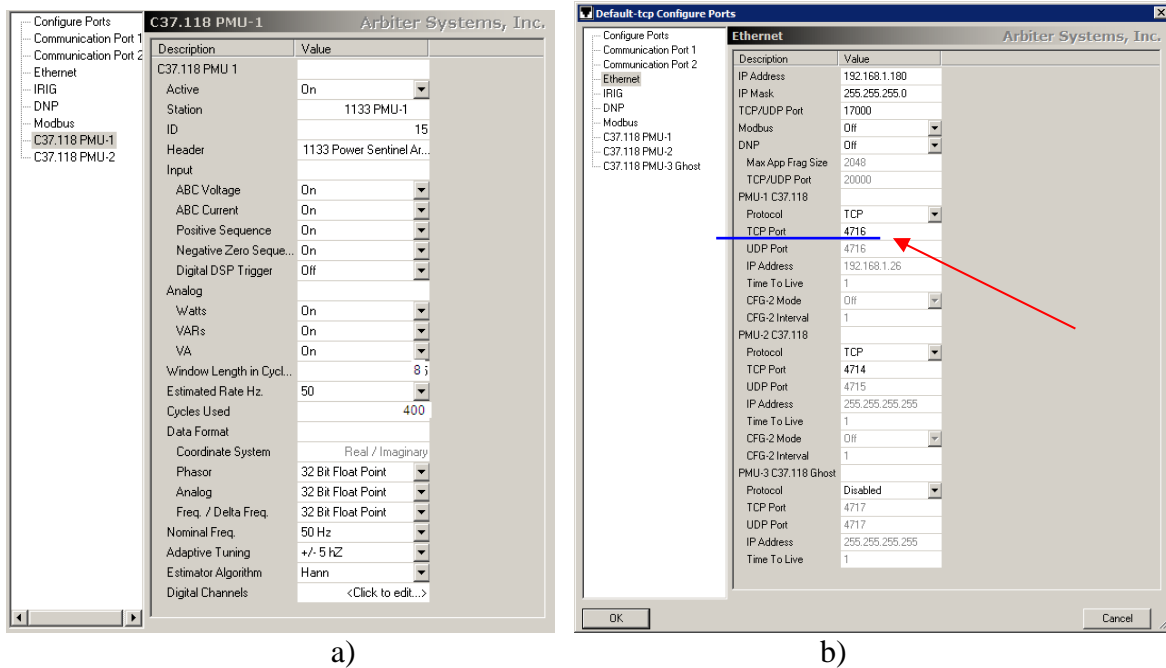

Figure 3

7.3.4.10 In the PSCSV™ software, select the Connection > Configure > Configure Measurement parameters menu in the DSP mode window that opens. Then select from the parameters offered those relating to the current connection and measurement parameters, including voltage, current, and a nominal frequency of 50 Hz. After completing configuration, click the Apply button to set the new values and the OK button to write the new values to the meter and close the dialog box.

7.3.4.11 In the UVITest program in the ini. file for the 1133A meter and the recorder, write:

- The IP addresses and TCP port numbers for communicating in the UVITest program and data transmission;
- the parameters to be measured and saved in text files;
- for the recorder in ini. file, record the number of the measuring unit in which the PMU function is enabled.

7.3.4.12 To verify the range and determine the measurement errors of the recorder in the PMU mode (Phasor Measurement Unit), assemble the circuit as shown in Figure 4a for the recorder with the PU16/32M4 unit Version 1, as shown in Figure 4b for the recorder with the PU16/32M4 unit Version 2

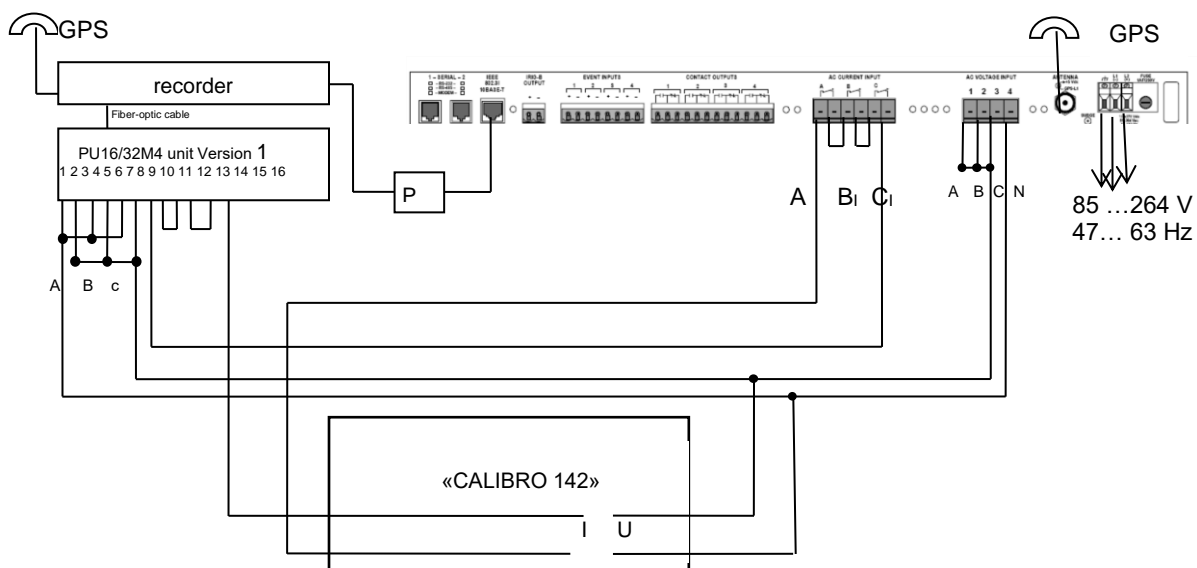

Figure 4a

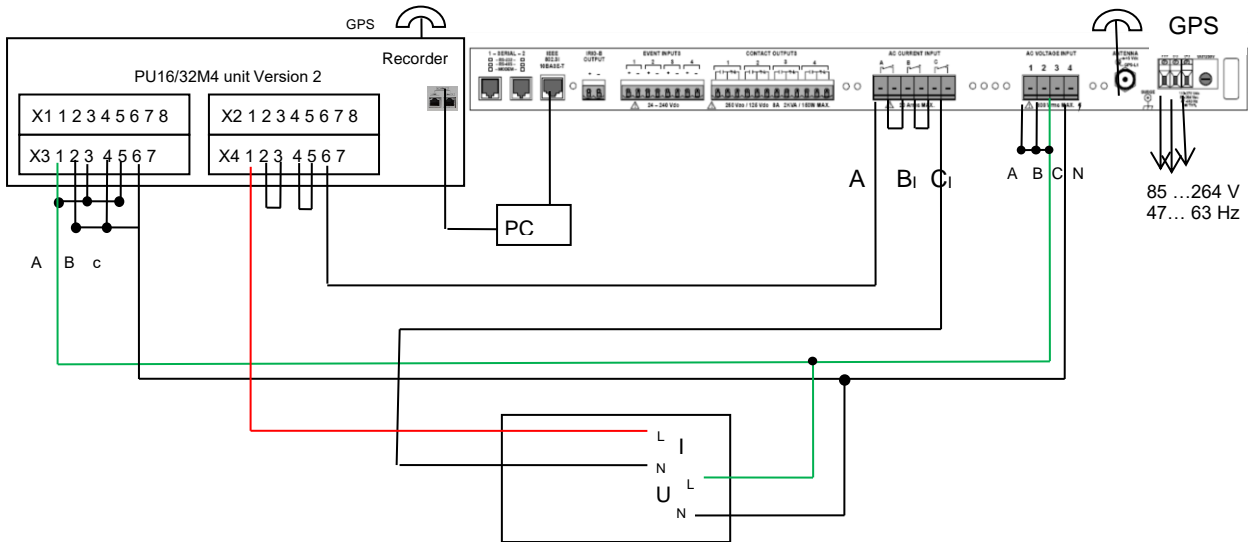

Figure 4b

7.3.4.13 Depending on the modules used in the PU16/32M4 units, select the values of the signals to be verified, form, and apply the first verified signal to the recorder inputs and the 1133A counter. The parameters of the verified signals are shown in Table 5.

Table 5

Signal number	f, Hz	φU°	Version 1				Version 2			
			U, V		I, A		U, V		I, A	
			140.0	460.0	1.4	6.5	140.0	460.0	2.0	11.0
1	50	0	14	46	0.14	0.65	14	46	0.2	1.1
2	50	45	42	138	0.42	1.95	42	138	0.6	3.3
3	50	60	70	230	0.7	3.25	70	230	1.0	5.5
4	50	240	105	230	1.05	4.785	105	230	1.5	5.0
5	50	180	140	230	1.4	6.5	140	230	2.0	5.0
6	50	-	-	345	-	-	-	345	-	-
7	50	-	-	460	-	-	-	460	-	-
8	50	-	-	-	-	-	-	-	-	8.25
9	50	-	-	-	-	-	-	-	-	11.0

7.3.4.14 Switch the «CALIBRO 142» calibrator to the power reproduction mode, form the first test signal, and apply it to the inputs of the 1133A meter and the recorder by pressing the OUTPUT key.

7.3.4.15 Launch UVIttest→START If connection and communication with the 1133A meter and the recorder are established correctly, the UVITest program will display the measured parameters; if the connection with the recorder or the meter is not established, the UVITest program will not start and a warning message will appear.

7.3.4.16 It is necessary to check the accuracy of the IP address and the recorder/counter's TCP port number, verify that it matches these parameters in the ini.file, and in they do not match, correct the parameters in compliance with the recorder and counter. Re-start the UVITest program, ensuring that when the START button is activated, communication with the 1133A meter and the recorder is established and the measured parameters are displayed in the UVITest software's information field.

7.3.4.17 If the voltage and current channels connection is correct, wait 1-2 seconds and then press the CHECK button. The program will automatically record the values of the first test signal measured by the recorder and the 1133A counter. Remove the test signal by pressing the STOP button.

7.3.4.18 In the same way, you can sequentially generate and issue test signals from the second to the fifth. After each test signal is formed, press START →CHECK →STOP successively in the UVITest software. Press the buttons at intervals of 1-2 s.

7.3.4.19 If the channels with the upper measurement range are used in the PMU mode, for example 140 V and 2.0 A, then verification is completed. Press the COMPLETE button in the UVITest software.

7.3.4.20 The UVITest software will automatically calculate the measurement errors, draw up the POVERKA file, and save it in the UVITest software in .csv format.

7.3.4.21 Open the POVERKA file using Excel and save it with the .xls extension.

7.3.4.22 Open the POVERKA file with the verification results of the PMU mode for a range of 140 V and 2 A, and view the verification results.

7.3.4.23 If channels with the upper measurement range are used for the PMU mode, for example 460 V or 11 A, then verification may continue.

7.3.4.24 Switch the «CALIBRO 142» calibrator to the AC voltage reproduction mode and sequentially form the sixth test signal, wait 1-2 seconds, and then press START →CHECK →STOP in the UVITest software.

7.3.4.25 Generate and apply the seventh test signal in the same way: wait 1-2 seconds and then press START →CHECK →STOP in the UVITest software.

7.3.4.26 Turn off the 1133A counter, switch the «CALIBRO 142» calibrator to the AC reproduction mode and sequentially form the eighth test signal, wait 1-2 seconds, and then press START →CHECK →STOP in the UVITest software.

7.3.4.27 Generate and apply the ninth test signal in the same way: wait 1-2 seconds and then press START →CHECK →STOP → COMPLETE in the UVITest software.

7.3.4.28 The UVITest software will automatically calculate the measurement errors, draw up the POVERKA file, and save it in the UVITest software in .csv format.

7.3.4.29 Open the POVERKA file using Excel to view the verification results; for additional work, save the file with the .xls extension.

7.3.4.30 If the channels for measuring DC voltage are used in the PMU mode for the PU16/32M4 units Version 2, then determine the metrological characteristics of the DC voltage.

7.3.4.31 Switch the «CALIBRO 142» calibrator to the DC voltage reproduction mode. Connect the channels for measuring the recorder's DC voltage 1000 V to the «CALIBRO 142» calibrator.

7.3.4.32 Form the first test signal for DC voltage on the calibrator in accordance with Table 6

Table 7

Specified parameter	Test signal, item No.					
	1	2	3	4	5	6
from -1000 to 1000	-1000	-500	-10	10	500	1000
from -0,2 to 0,2	-0.2	-0.1	-0.02	0.02	0.1	0.2

7.3.4.33 Start the UVITest software, measure the DC voltage, then press START →CHECK →STOP in the UVITest software.

7.3.4.34 Similarly, establish a test signal of the DC voltage from the second to the sixth, measure it, and determine the measurement errors. Record the measurement and calculation results in the verification report.

7.3.4.35 Remove the voltage, disconnect the channel for measuring DC voltage 1000 V, and connect the channel for measuring AC current 0.2 V to the «CALIBRO 142» calibrator through the P321 resistance coil with the nominal value of 0.1 Ω.

7.3.4.36 On the «CALIBRO 142» calibrator, form a DC voltage test signal in accordance with Table 5 for the 0.2 V range and apply it.

7.3.4.37 Start the UVITest software and measure the DC voltage.

7.3.4.38 Similarly, from the second to sixth test signal, measure the DC voltage and determine the measurement errors for the 0.2 V DC voltage range. Record the measurement and calculation results in the verification report.

7.3.4.39 The verification results shall be deemed favorable if the errors of the recorder when measuring parameters in the PMU mode meet the permissible measurement errors given in the type specification; otherwise, further verification is terminated and the recorder is considered not to have passed.

Section 7 (Revised edition, Amendment No. 1)

8 PROCESSING THE MEASUREMENT RESULTS

8.1 The relative measurement errors are calculated according to formula (1), reduced measurement errors are calculated according to formula (2), and the absolute measurement errors are calculated according to formula (3)

8.2 When calculating the error values, the number of digits of the calculation result should be one more than the number of digits of the permissible error values.

8.3 The verification results shall be deemed favorable if the parameters of the verified recorder meet the permissible errors given in the type specification; otherwise, further verification is terminated and the recorder is considered not to have passed.

9 DOCUMENTING THE VERIFICATION RESULTS

9.1 The verification results are documented in a report. The form of the report is arbitrary, appendices to the report of primary and periodic verification of analog channels of PU16/32M4 units are generated by the recorder's internal software; to check the parameters of the PMU function, use the UVITest software.

9.2 The verification certificate is issued for the positive verification results during the initial verification.

9.3 The verification certificate should indicate the measurement ranges according to which the recorder was verified, as well as information that "verification was carried out in the scope of the performed examination".

9.4 The verification mark is applied on the log-book and/or verification certificate as an imprint and holographic verification sticker.

9.5 If the results of the periodic verification are negative, the verification certificate is not issued, and the unsuitability notification is issued in accordance with the regulatory documents of the Federal Agency on Technical Regulating and Metrology.

Head of the Department 206.1

S.Yu. Rogozhin

_____ 2020.

Head of the 206.1 department

M.V. Grishin

_____ 2020.